

WLL 1850 kg

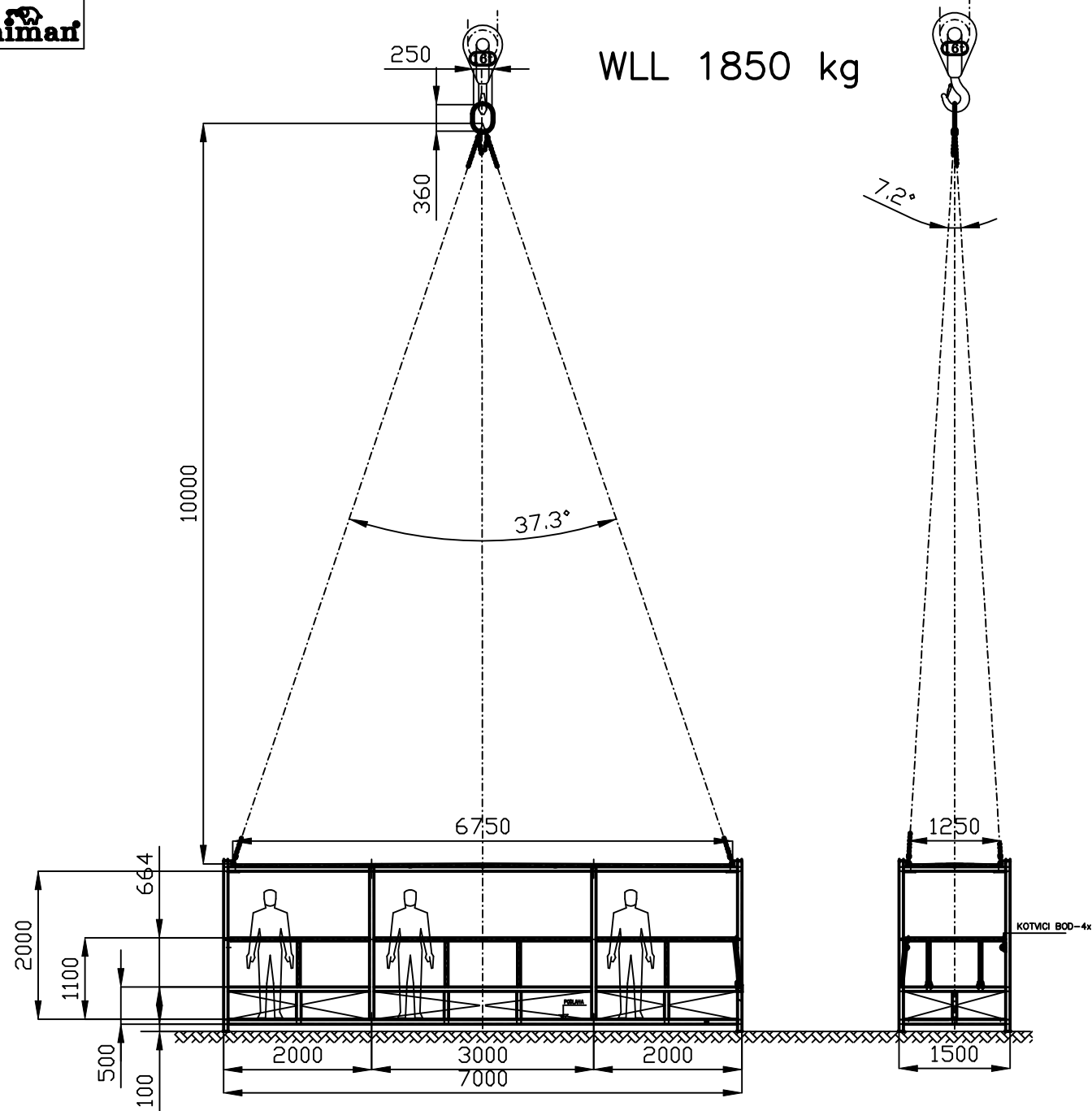

TECHNICAL DATA

TYPE	ZKR 1850/7x1,5	
CODE	
CAPACITY (WLL)	Q (kg)	1850
CAPACITY OF CRANE	Q1 (t)	16
LENGTH	L (mm)	7000
WIDTH	B mm	1500
HEIGHT OF SUSPENSION	t mm	12000
INTERNAL HEIGHT	H mm	2000
DEAD WEIGHT	G (kg)	850
Nr.OF CYCLES PER YEAR	20 000 c/y	

SUSPENDED ACCESS BASKET ZÁVESNÁ KLEC REVIZNÍ